

## 2.2 Single components for automation and testing technology

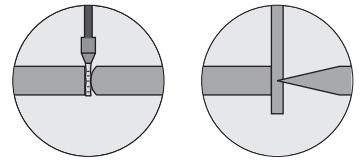

### Special version for bonding thin conductors, wires, etc.

#### Function

The bonding outlet is closed when the compressed air is switched on. The conductor, strand, etc. can be inserted after pressing the LKT button. Conductor bonding takes place after releasing the button. Bonding is performed using a clamping piston which makes contact to the conductor.

For not bared line ends, the connection is made using a steel tip piercing through the insulation and making connection to the conductor.

#### Order data

To ensure safe bonding of the conductor, the bonding outlet has to be adjusted to the conductor outer diameter.

Indicate the diameter (0.1 mm precision).

We adjust the locating hole so that the conductor can be inserted easily and safe bonding is also ensured.

#### Order example

**LKT-S8-D2,5-0F2** for conductor of 2.0 mm diameter.

We manufacture the bonding module e.g. with a 2.5 mm locating hole.

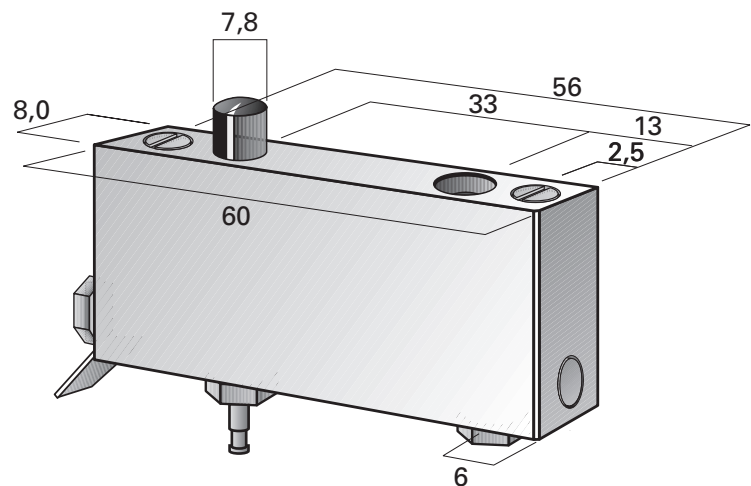

#### Note

In all but the case width, the dimensions correspond to the LKV-12 standard module.

Refer to the data sheet: Available types of cases.

**Please take note of our special accessories such as pneum. central opener, compressed air distributor.**